



For Earth, For Life  
Kubota

# SVL

## KUBOTA COMPACT TRACK LOADER SVL75-2 / SVL95-2s

The outstanding power and exceptional comfort of Kubota's new Compact Track Loaders take high performance and productivity to a new level.



# Need more productivity? Put the all-new Kubota Compact Track Loader to work for you.

Kubota, a trusted and world-leading manufacturer of construction equipment, is proud to introduce the all-new SVL75-2/SVL95-2s Compact Track Loaders. These new compact track loaders deliver best-in-class bucket breakout force and lifting capacity, outstanding stability, a wide and comfortable operator area, and much more. When it comes to high performance, reliability and comfort, the road leads to Kubota.

- **OUTSTANDING PERFORMANCE**
- **EXCEPTIONAL COMFORT**
- **EASY MAINTENANCE AND IMPRESSIVE DURABILITY**

## **SVL75-2**

Engine gross horsepower (SAE J 1995): 74.3 HP (55.4 kW)  
Rated operating capacity (35% of tipping load) : 2300 lbs (1043 kg)  
Bucket breakout force : 6204 lbs (2814 kg)  
Operating weight (Including operator weight 165 lbs) : 9039 lbs (4100 kg)



# COMPACT TRACK LOADER SVL75-2/SVL95-2s



## SVL95-2s

Engine gross horsepower (SAE J 1995): 96.4 HP (71.9 kW)  
Rated operating capacity (35% of tipping load) : 3200 lbs (1451 kg)  
Bucket breakout force : 7961 lbs (3611 kg)  
Operating weight (Including operator weight 165 lbs) : 11299 lbs (5125 kg)



# OUTSTANDING PERFORMANCE

## Kubota engine

### Common Rail System and Diesel Particulate Filter (DPF) Muffler

The Common Rail System (CRS) electronically controls the fuel injection timing and amount in stages rather than all at once for optimal combustion; resulting in greater efficiency, better fuel economy and less engine noise.

The combination of Exhaust Gas Re-circulation (EGR) and Diesel Particulate Filter (DPF) reduces the emissions making the SVL Series engine Tier IV certified.

#### ● Powerful Kubota engine

The powerful and reliable Kubota-built engine gets the job done quickly and easily with 74.3 hp\* (SVL75-2) or 96.4 hp\* (SVL95-2s).

\* Engine HP Gross (SAE J 1995)

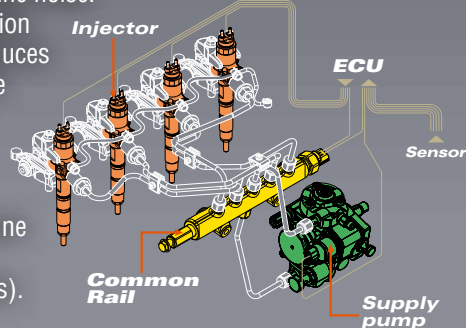

#### ● SCR meter panel

An SCR system helps the SVL95-2s meet Final Tier4 requirements. A quick glance at the digital panel tells you how much Diesel Exhaust Fluid (DEF) remains in the tank and also when to refill it.





	<b>SVL75-2</b>	<b>SVL95-2s</b>
<b>Bucket Breakout Force:</b>	<b>6204 lbs</b>	<b>7961 lbs</b>
<b>Arm Breakout Force:</b>	<b>4766 lbs</b>	<b>6742 lbs</b>
<b>Tipping Load:</b>	<b>6570 lbs</b>	<b>9143 lbs</b>

● **Automatic regeneration system**

Kubota's original automatic regeneration system automatically burns accumulated particulate matter (soot) in the DPF muffler to keep the muffler clean for longer operation. For operational and safety reasons, automatic regeneration can be turned off with the inhibit switch when compact track loader is operating in areas that are near people, animals, and flammable materials.



● **Electronic Travel Torque Management**

Electronic Travel Torque Management System lets you work faster with more power. The ECU constantly monitors the load of the machine to optimally control hydraulic pump output according to the load, preventing engine stalls for smoother operation even under severe conditions.

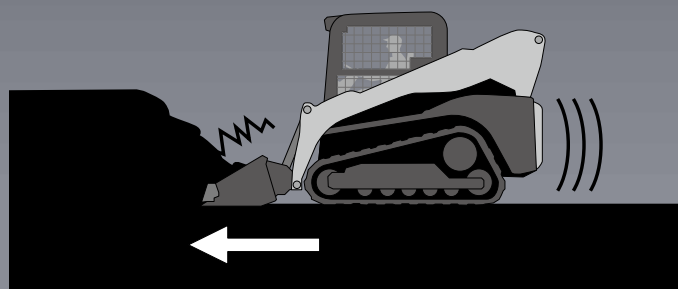

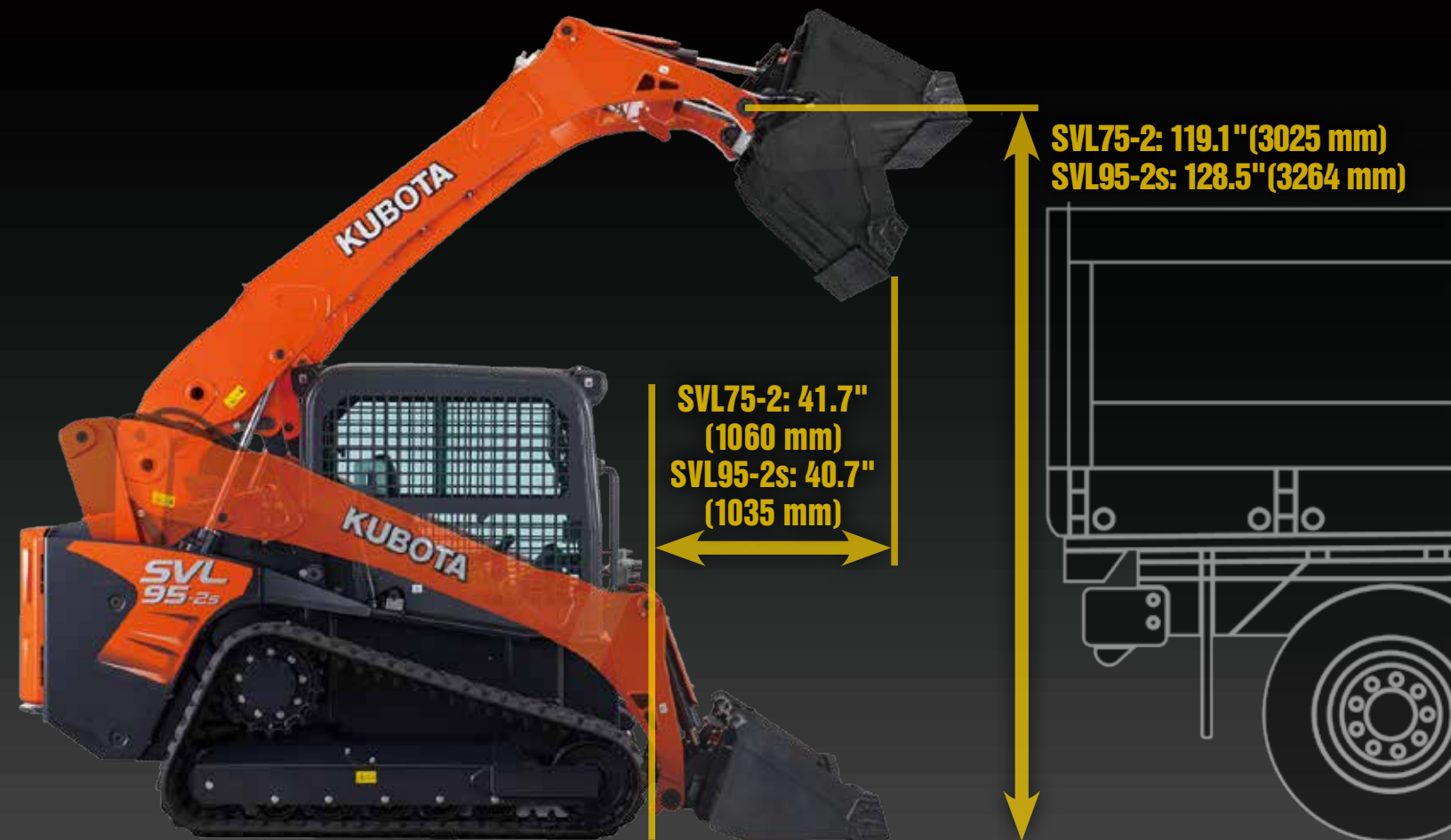

# Kubota Unique Vertical Lift Design



- Long Reach for Maximum Lifting and Dumping
- High Bucket Hinge Pin Height

Kubota's unique vertical lift is designed to deliver an exceptionally long reach of 41.7 inches (SVL75-2) and 40.7 inches (SVL95-2s). In addition, the tip of the arm is optimally shaped for a tall hinge pin height of 119.1 inches (SVL75-2) / 128.5 inches (SVL95-2s) for easy dumping into trucks.



- Standard Self-leveling Function

This feature helps keep the bucket or fork in a horizontal position without the need to manually adjust the angle during lifting.

# Travel Performance

## Standard Two-speed Travel

Shift from low gear at 4.7 mph (SVL75-2) / 5.0 mph (SVL95-2s) to high gear at 7.1 mph (SVL75-2) / 7.3 mph (SVL95-2s) to get the job done faster.

## Pilot Valve with Shuttle Piston

This ensures consistent oil flow which improves stability when going straight.

## Higher Ground Clearance

A high ground clearance of 11.7 inches (SVL75-2) / 11.5 inches (SVL95-2s) lets you travel over large obstacles with ease.

## Strong Traction Force

Kubota's original track lug design gives you more grip and a stronger traction force of 9678 lbs (SVL75-2) / 12178 lbs (SVL95-2s).

# Excellent versatility

## ● Multi-function levers

The multi-function levers provide fingertip control of all major vehicle and attachment operations, letting you keep both hands on the levers at all times for optimal operating efficiency.

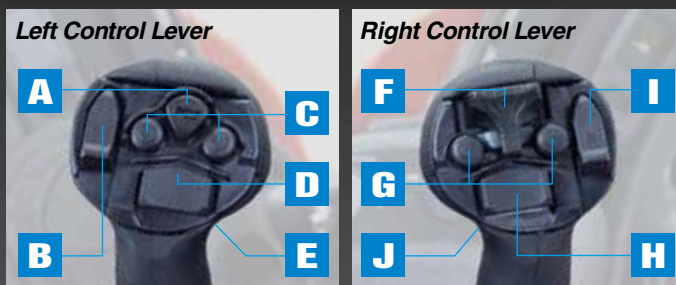

## ● High-flow Hydraulics (Option)

Having high flow increases the hydraulic muscle for attachments that need more hydraulic horsepower. With this option auxiliary hydraulic flow increases to 29.3 gpm (SVL75-2) / 40 gpm (SVL95-2s). The coupler manifold includes both 1/2" and 3/4" couplers.

### Aux. hydraulic flow

SVL75-2	Std.	17.4 gpm (66 lpm)
	High	29.3 gpm (110.9 lpm)
SVL95-2s	Std.	23.1 gpm (87.6 lpm)
	High	40 gpm (152 lpm)



# Powerful hydraulic system

## ● Load Sensing System (SVL95-2s)

## ● Enhanced Control Valve System (SVL95-2s)

The SVL95-2s features a new Load Sensing System and improved control valve to provide even more powerful pushing and driving forces, even for combined attachment operations. Plenty of power to travel on slopes and handle attachment work also means you'll get the job done faster.

## ● Adjustable Maximum Oil Flow Control (Option) (SVL95-2s)

Quick and easy 5 modes of the AUX flow ensures the optimal flow rate for every job you do. Adjustable Maximum Oil Flow Control is available only for high flow.



# EXCEPTIONAL COMFORT

## Comfortable Cab

### ● Wider Cab Entrance

A wider entrance makes it easier to get in and out.

### ● Wide And Clean Cab

The spacious interior minimizes fatigue even during long work hours.

### ● High-back Full Suspension Seat

The standard suspension seat offers outstanding comfort. (Air Suspension seat is optional)

### ● Arm Rest

The spacious cab also includes ergonomically placed arm rests on the right and left sides of the seat to minimize operator fatigue. The arm rests have been designed to increase operator space.

### ● Wide Leg Room

The cab provides ample leg room to reduce operator fatigue.

### ● Ready for radio installation (Option)

The SVL-series Factory Closed cab now comes prewired with speakers already installed, all that needs to be added is the radio.

### ● Easy-clean Floor Mat and Drain Outlet

The soft rubber floor mat is easy to remove and clean. And with the built-in drain outlet, the mat can be washed in the cab.





# Excellent 360° Visibility

The edge of the bucket can be seen from the seat. Improved visibility translates to better safety on the job.



## ● Hand/Dial and Foot Throttle

The SVL95-2s' dial and foot throttle, and the SVL75-2's hand and foot throttle both allow you to match the engine speed to the task. The hand/dial throttle is ideal for jobs requiring constant engine speed such as cold planing, trenching or snow blowing. The foot throttle lets the operator vary engine speed for other applications.



(SVL75-2)



(SVL95-2s)



(SVL75-2/SVL95-2s)

# EXCEPTIONAL COMFORT

## Pressurized Cab

The cab is pressurized to keep dust, flying debris, and insects away to enhance comfort on the job. Furthermore, noise is kept down to let you work for long hours with minimal fatigue.



## Excellent Air Conditioning Performance

### ● Optimized Air Conditioning

Thanks to improved vents, the climate control system provides an optimized airflow for outstanding cooling and heating performance—and supreme operator comfort—all year round.

### ● Enhanced Defrosting and Demisting Functions

Ample airflow prevents the windows from fogging up or freezing during the cold months of the year.



# CAB

## Easy-open Sliding Windows

The sliding front door can be opened regardless of the position of bucket or attachment; allowing you to get in or out in difficult situations and also work with the front door open. It is a added benefit when hooking up attachments, improving the visibility and safety.

The sliding side windows are split in the middle and can be opened separately from the front or rear.



# EASY MAINTENANCE IMPRESSIVE DURABILITY

## Easy Maintenance

- **Routine Checks**

Simply open the rear bonnet to access all components for daily routine inspections.

- **Slide-and-tilt Radiator and Oil Cooler**

The radiator can be tilted for easy cleaning.

- **DEF easy refill access (SVL95-2s)**



- **Tilt-up Cab**

The cab can be tilted 72° without having to lift the arm, allowing easy access to the hydraulic pumps, valves, lines and hydraulic tank.



- **Large Space for Tool Box**

The SVL75-2 offers a convenient and large tool box for storing a grease gun and other necessities.



# ANCE & DURABILITY

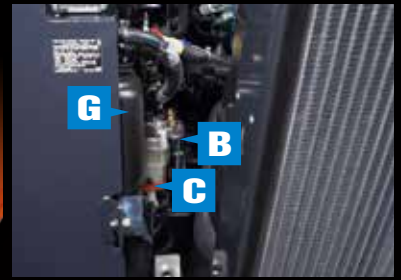

- A. Dual Element Air Cleaner**
- B. Fuel Filter**
- C. Water Separator**
- D. Maintenance-Free Battery**
- E. Coolant**
- F. Slide-and-tilt Radiator**
- G. DEF tank**

## Diesel Particulate Filter (DPF) and Selective Catalytic Reduction (SCR)

The Diesel Particulate Filter and Selective Catalytic Reduction meet the latest Tier4 diesel emissions regulation by collecting particulate matter (PM) and NOx from exhaust gas for cleaner exhaust emissions.



## Impressive Durability

### 1. Welded, Integrated Mainframe and Undercarriage

The undercarriage forms an integral part of the main frame for maximum durability.

### 2. Kubota Original Rubber Tracks

Kubota's original rubber tracks offer outstanding durability and long-life performance. Furthermore, Kubota's original lug pattern prevents soil from accumulating and improves traction force. 15" (380 mm) wide tracks are optional for the SVL75-2.

### 3. Triple Flange Lower Track Rollers

A highly reliable triple flange design not only minimizes the risk of detracking, but improves stability as well. They are lifetime sealed and lubricated.



1

2

3

# VERSATILITY

With a wide variety of attachments available\*, Kubota Compact Track Loaders are the most versatile machine on your jobsite.

*\*Not all attachments are OEM-KUBOTA.*

**Auger**



**Grapple Bucket**



**Quick Coupler**

An optional Hydraulic quick coupler is available. You can attach or remove attachments using a switch without leaving the seat.



**Pallet Fork**



**Sweeper**



**Heavy Duty Bucket**

**Sweeper**

**4-in-1 Bucket**

**Snow Blade**

**Breaker**

**Rotary Tiller**

**Grader Scraper**

**Snow Blower**

**Rotary Cutter**

**Tree Puller**

**3-pt hitch adapter**

## EQUIPMENT

### STANDARD EQUIPMENT

- Open CAB (ROPS / FOPS Level 1)
- Top / Rear window
- Suspension seat
- 2" Retractable seat belt
- Operator presence control
- Pull down arm rest
- Hand/Dial and Foot throttle
- 12V electric outlet
- Horn
- Lockable fuel cap
- Backup alarm
- Working lights (Front 2 / Rear 2)
- Glow plug
- Mechanical quick coupler
- Loader arm float function
- Bucket self-leveling (up only)
- Wet disc parking brakes
- Two-speed travel
- Rubber crawler SVL75-2-12.6" (320mm)
- SVL95-2s-17.7" (450mm)

### OPTIONAL EQUIPMENT

- High-flow hydraulics (1/2" and 3/4" couplers for both models)\*
- Adjustable maximum oil flow\*
- 14-pin coupler for attachments
- Wide rubber crawler\* SVL75-2-15" (380mm)
- Radio Ready\*
- Air ride suspension seat
- 3" Retractable seat belt
- Rear bonnet lock Kit
- Rear view mirror
- Hydraulic quick coupler\*
- Strobe light
- Beacon light
- Engine block heater
- Radiator screen
- ...and much more.

\*Factory Option

# SPECIFICATIONS

Model		SVL75-2		SVL95-2s	
Type of operator station		Open CAB / Closed CAB		Open CAB / Closed CAB	
Engine	Model	V3307-CR-TE4		V3800-TIEF4	
	Emission certification	Tier 4		Tier 4	
	Gross HP (SAE J1995)	HP (kW)/rpm	74.3 (55.4)/2400	96.4 (71.9)/2400	
	Net HP (SAE J1349)	HP (kW)/rpm	68.8 (51.3)/2400	87.0 (64.9)/2400	
	Displacement	cu.in. (cc)	203.3 (3331)	230.0 (3769)	
	Cylinders		4	4	
	Bore × Stroke	in.(mm)	3.7 (94) × 4.72 (120)	3.94 (100) × 4.72 (120)	
Aspiration		Turbocharged	Turbocharged		
Loader Performance	Rated operating capacity-35% tipping load		lbs. (kg)	2300 (1043)	3200 (1451)
	Rated operating capacity-50% tipping load		lbs. (kg)	3285 (1490)	4572 (2074)
	Tipping load		lbs. (kg)	6570 (2980)	9143 (4147)
	Breakout force	Bucket	lb. (kg)	6204 (2814)	7961 (3611)
		Lift arm	lb. (kg)	4766 (2162)	6742 (3058)
Lift arm path			Vertical	Vertical	
Undercarriage	Track Width	Standard	in. (mm)	12.6 (320)	17.7 (450)
		Wide	in. (mm)	15.0 (380)	N/A
	Ground pressure	Standard	psi	5.6 / 5.8	4.4 / 4.5
		Wide	psi	4.7 / 4.9	N/A
	Track rollers (per side)			4	5
	Track ground contact length		in. (mm)	56.5 (1436)	65.6 (1667)
	Travel speed	Low	mph (km/h)	4.7 (7.5)	5.0 (8.0)
		High	mph (km/h)	7.1 (11.5)	7.3 (11.7)
Traction force		lbs. (kg)	9678 (4390)	12178 (5524)	
Min. ground clearance		in. (mm)	11.7 (296)	11.5 (293)	
Hydraulic system	Aux. hydraulic flow	Std./High	gpm (ℓ/min.)	17.4 (66.0) / 29.3 (110.9)	23.1 (87.6) / 40.0 (152)
	Aux. hydraulic pressure		psi (kgf/cm <sup>2</sup> )	3185 (224.0)	3553 (249.8)
Service refill capacities	Hydraulic system		gal. (ℓ)	15.9 (60)	17.96 (68)
	Hydraulic tank		gal. (ℓ)	9.2 (35)	10.1 (38.1)
	Fuel tank		gal. (ℓ)	24.6 (93)	28.8 (109)
	DEF tank		gal. (ℓ)	N/A	5.0 (18.8)
Operating weight (Includes operator weight 165lbs.)		lbs. (kg)	9039 (4100) / 9315 (4225)	11299 (5125) / 11574 (5250)	

# DIMENSIONS

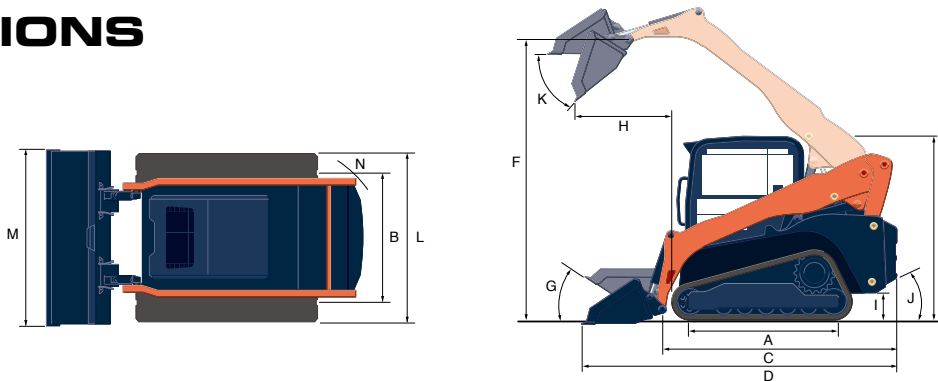

Model		SVL75-2		SVL95-2s	
A	Length of track on ground	in. (mm)	56.5 (1436)	65.6 (1667)	
B	Track gauge	in. (mm)	53.3 (1355)	59.5 (1512)	
C	Length w/o bucket	in. (mm)	109 (2768)	123.5 (3137)	
D	Length w/bucket on ground	in. (mm)	140.8 (3576)	154.6 (3929)	
E	Height to top of cab	in. (mm)	82 (2083)	83.3 (2116)	
F	Bucket hinge pin height at max. lift	in. (mm)	119.1 (3025)	128.5 (3264)	
G	Rollback angle at carry position	degree	27	27	
H	Reach at max. lift and dump	in. (mm)	41.7 (1060)	40.7 (1035)	
I	Ground clearance	in. (mm)	11.7 (296)	11.5 (293)	
J	Departure angle	degree	31.5	31	
K	Max. dump angle	degree	40	43	
L	Vehicle width	Standard track / Wide track	in. (mm)	65.9 (1675) / 68.3 (1735)	
M	Width with bucket		in. (mm)	68 (1727) / 80 (2032)	
N	Turning radius from center-machine rear		in. (mm)	107.1 (2720) / 127 (3220)	



**KX080-4S**

***From our excavators, skid steers and wheel loaders to our tractor/loader/backhoes, Kubota offers a wide range of reliable, high-performance construction equipment to get the job done right.***



**M62**



**SSV65/SSV75**

Kubota Tractor Corporation reserves the right to change the stated specifications without notice. This brochure is for descriptive purposes only and reasonable efforts were used to set forth the contained information; some items shown may be optional and some products shown may not be available at all dealerships. Kubota disclaims all representations and warranties, express or implied, or any liability from the use of this brochure. For complete warranty, safety and product information, consult your local Kubota dealer and the operator's manual. Power (HP/KW) and other specifications are based on various standards or recommended practices. For your safety, Kubota strongly recommends the use of a Rollover Protective Structure (ROPS) and seat belt in almost all applications. This brochure is intended for the United States and US territories only. For information regarding Kubota products or services outside these areas, see Kubota Corporation's global web site. Kubota does not provide parts, warranty or service for any Product which is re-sold or retailed in any country other than the country for which the Product(s) were designed or manufactured.

©2017 Kubota Corporation



**KUBOTA TRACTOR CORPORATION**

1000 Kubota Drive, Grapevine, TX 76051 Tel 888-4 KUBOTA

Visit our web site at: [kubotaUSA.com](http://kubotaUSA.com)

